

# TranSTAR Transporter

## Changing the Way You Inspect Pipelines

RS Technical Services adds to the family of mainline tractor transport vehicles with the TranSTAR. Innovative technology utilizes easy access on the transporter chassis to exchange the motor drive gear set when a change in motor torque is needed. Steerable and non-steerable versions available. Allows inspection of line sizes 6" to 30".

Note: See your distributor for other camera options.

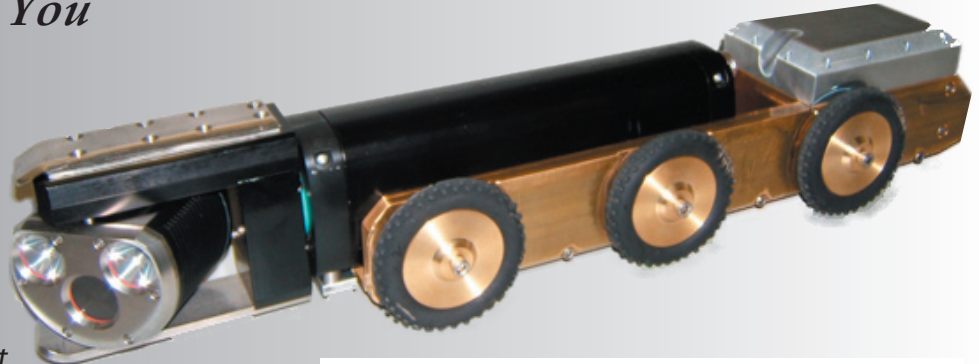

**Indian River Equipment Company**  
2111 Smith Avenue  
Chesapeake, Virginia 23320  
(757) 424-5656

### Features

- **Quick Change Gears**  
Accessible motor drive gear on transporter chassis. Install gear sets of alternate ratios to optimize the transporter for the existing or potentially changing load conditions.
- **All Wheel Drive**  
Gear driven wheels employing ball-bearing supported steel precision machined gears encased in brass. Sealed hubs prevent moisture or dirt from entering gear case.
- **Freewheel Clutch**  
Neutral gear allows rapid retrieval without the need to coordinate Transporter speed with Cable reel speed.
- **Rare-Earth Permanent Magnet Motor**  
Rated at 1/8 HP (90 watts, continuous) to provide a smooth, powerful drive source.
- **Single Conductor Coax Control**  
Speed control and DC power from single conductor coax TV cable.
- **Torque Multiplier Circuit**  
Internal control when that extra boost is needed.
- **Precision Machined Construction**  
CNC precision machined brass 360 plate gear housing shafts and stainless steel hubs.
- **Large Size Tires Available**
- **Optional Extension Sets**

### Specifications

- **Environmental Operating Conditions**  
Water resistant per IPX7  
Temperature: -10° to +40°C
- **Power Requirements**  
Operates on all standard RST single conductor systems. Optional multi-conductor is available.
- **Maximum Input**  
180 watts (peak), 1.5 amps
- **Maximum Pipe Size**  
(Adjustable with optional axle and wheel combinations)
- **Speed Range**  
5 to 70 feet per minute (fpm)
- **Dimensions**  
Overall Length: 18.9"  
Wheel Base: 11.0"  
Width: 4.2"  
Height: 4.2"  
Base Weight: 25.0 lbs  
(Without OMNI EYE III Camera)



www.rstechserv.com  
800.767.1974

• sales@rstechserv.com  
• (Fax) 707.778.1981

*Reliability*  
*Satisfaction*  
*Technology's Leading Edge*

# TranSTAR Transporter

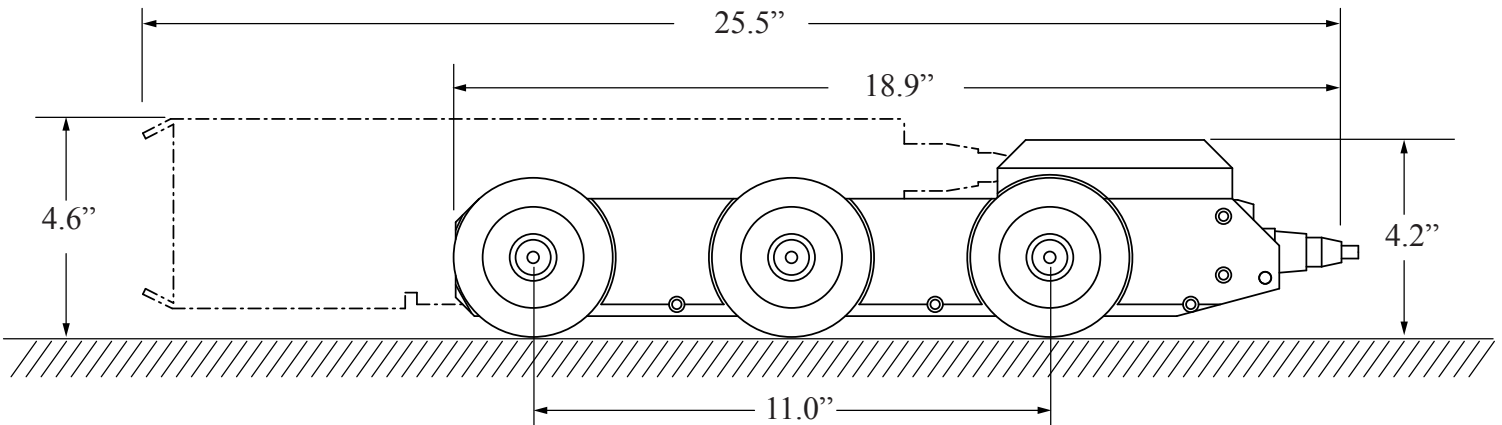

## Side View Dimensions\*

\* Dimensions shown with and without OMNI EYE III Camera

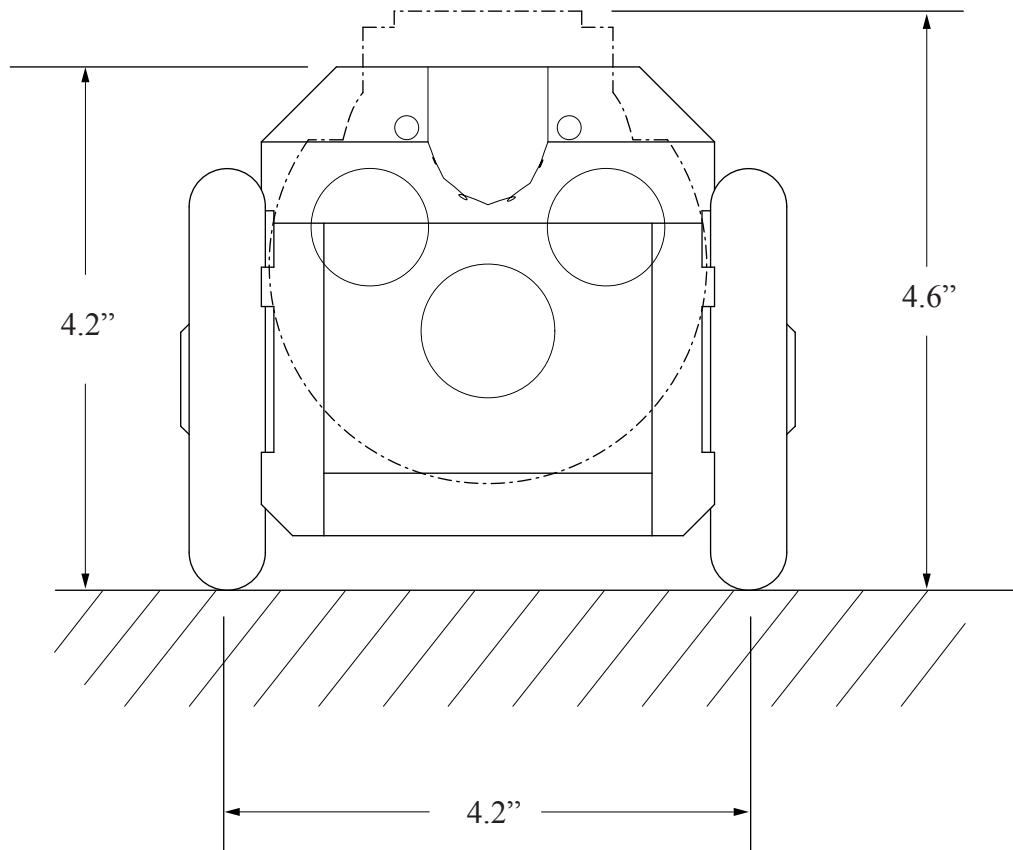

## Front View (with OMNI EYE III Camera)



Indian River Equipment Company  
2111 Smith Avenue  
Chesapeake, Virginia 23320  
(757) 424-5656